

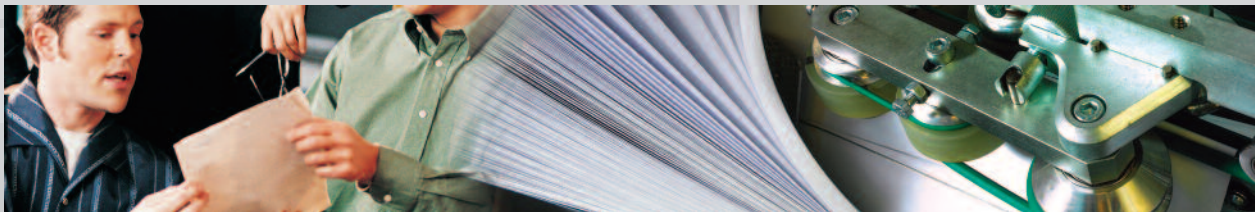

Integrated Bindery Systems

Book finishing systems for digital print



Comprehensive service and support
A commitment to engineering excellence
Worldwide system installations

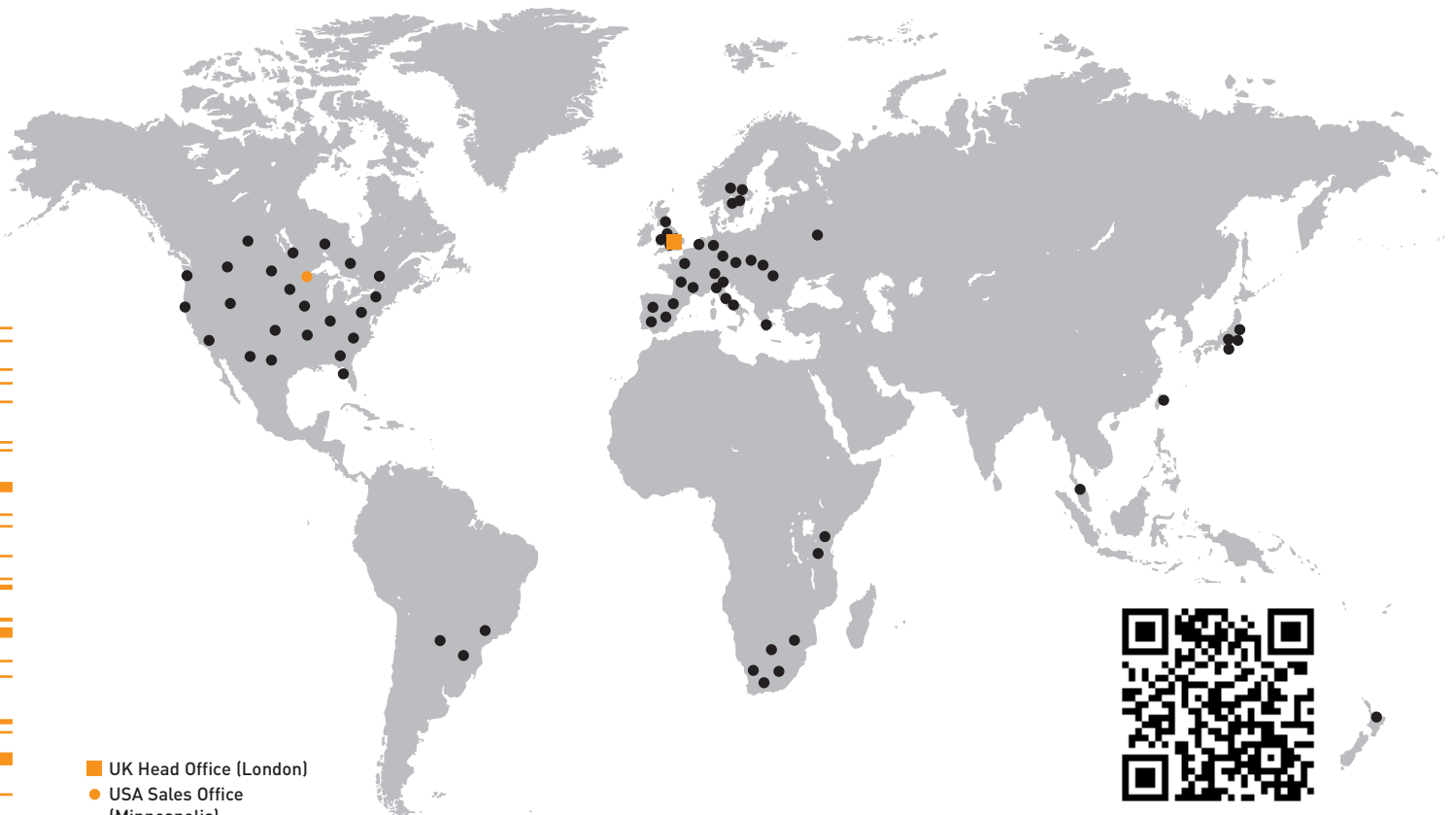

- UK Head Office (London)
- USA Sales Office (Minneapolis)
- IBIS Installed Products



www.ibis-bindery.com

IBIS Bindery Systems

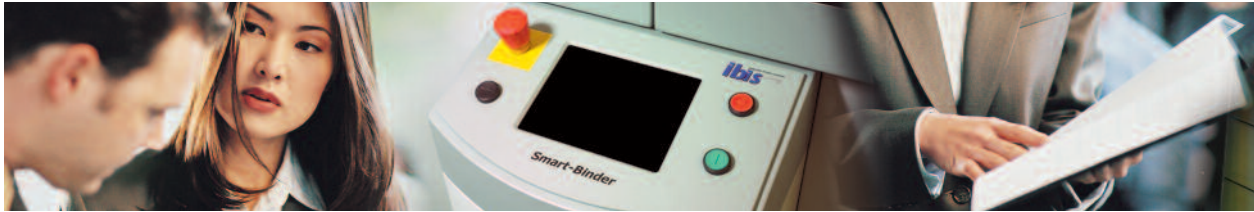

Who we are and what we do

Since its start-up in 1999, IBIS Bindery Systems has become a leading worldwide supplier of digital book finishing systems for digital print, based on the 'Smart-binder' brand name.

We have grown a strong reputation in the market place for reliable, durable and innovative solutions. We also excel in customising both modules manufactured by IBIS and also from other vendors and linking these together into complex and specialised systems to meet specific customer needs.

Our IBIS team has over 200 man-years design experience in book finishing solutions. We are dedicated to providing innovative and high performance equipment with unique features and user advantages.

The IBIS Senior Management team

The IBIS senior management team includes two Oxford and Cambridge Engineering Graduates:



John Cracknell Managing Director
32 years experience in Print Finishing, including 20 years as Engineering Director with Heidelberg, AM and Harris.



Mark Firth Engineering Director
25 years experience in Print Finishing, specializing in system control.



Martin Reed Customer Support Director
27 years experience of book binding machinery manufacture and supply.

Our focus has been on finishing solutions for high-speed CF (web) digital printers, both off-line and in-line. We also offer book finishing solutions for use with cut-sheet printers.

Uniquely, we offer the ability to produce both glued books and wire stitched (stapled) books from the same machine. In this way we provide a one-stop service for book finishing solutions. All our products are backed by first-class customer training and support.

We are based 30 miles (48 km) from central London and close to Heathrow international airport.



IBIS Head Office and showroom, High Wycombe, UK

Our purpose and values

Our Purpose

To bring new opportunities and commercial advantage to our customers.

Our Values

Commitment:

We are committed to bringing success to our customers.

Openness:

We communicate honestly and frankly.

Integrity:

We conduct ourselves correctly and deliver what we promise at all times.

Technical excellence:

We take pride in high standards of engineering and providing maximum benefits to end-users.



Why buy from IBIS?

Because we will give you real advantage over your competitors by:

Reducing your production costs

- In-line or off-line operation.
- Up to 2440 pages/min throughput (up to 12,000 books/hr output).
- Stitched *and* glued books up to 60mm (2.36") thick from the same machine.
- Low running costs.

Enhancing your book quality

- Individual sheet folding for better lay-flat of saddle-bound books up to 200 pages.
- ISG cold gluing available for increased strength and improved lay-flat.
- Three-side trimming.
- Square-backed perfect bound books (SB-4 only) with 4-scored covers and wheel side-glue.
- Bar code sheet tracking and auto-reject for guaranteed book page integrity.

Smart-binder output



- Saddle-stitched books up to 10mm (0.4") thick.



- Saddle-glued books up to 10mm (0.4") thick – ISG Cold Glue.



- Square-back books made with cold & hot glue up to 60mm (2.36") thick.

Sprint-binder output



- Square-back perfect bound books up to 60mm (2.36") thick – hot-melt or PUR glue only.

Increasing your up-time

- Very robust, high quality machine construction for 7 x 24 hr, reliable operation.
- Easy and quick to maintain.
- Focus on operator and maintenance training.

Providing support and customisation

- Highly skilled specialist field engineers.
- Technical support by phone and email.
- First level on-site support from digital printer vendors.
- Large range of special options and added value features.
- Special engineering to customise systems to your specific needs.



Product Range

Smart-binder	Model	Max. Input Speed (A4 pages/min)	Wire Stitching	ISG Cold gluing	ISG Cold glue & Hot melt glue	Max book thickness
For saddle stitched, saddle glued and/or perfect bound books	SB-1	400	✓	x	x	10mm (0.4")
	SB-1G	400	✓	✓	x	10mm (0.4")
	SB-1G4	400	✓	✓	✓	60mm (2.36")
	SB-2	1200 (or 2400 with extra folder)	✓	x	x	10mm (0.4")
	SB-3		✓	✓	x	10mm (0.4")
	SB-4		✓	✓	✓	60mm (2.36")
	SB-5		✓	✓	✓	60mm (2.36")
SB-5	✓		✓	✓	60mm (2.36")	

Sprint-binder	Model	Throughput	Number of Clamps	Gluing Options	Max book thickness
For perfect bound books only	PB-600C	400 pages/min (input)	1	hot melt or PUR	60mm (2.36")
	PB-600S	400 books/hr	1	hot melt or PUR	60mm (2.36")
	PB-2000J	1500 book/hr	4	hot melt or PUR	40mm (1.6")

Features

- In-line connection with highest speed digital printers, or off-line operation from a high speed sheet feeder, or roll unwinder.
- Individual sheet folding for optimum saddle-bound book quality.
- Cover and Insert sheet feeding.
- Bar code tracking of all sheets and auto-rejection of bad books, to ensure integrity.
- Book page count variable on the run (Smart-binder and PB-600).
- Three-knife trimming with optional centre-knife for Smart-binder.
- Heavy duty construction for 24 x 7 operation.
- Easy-to-use touch-screen controls.
- Complete range of book format sizes.
- Optional sheet dynamic micro-perforation and hole punching for Smart-binder.

Specifications	SB-1	SB-2	SB-3	SB-4	PB-600C	PB-600S	PB-2000J
Max. input speed	250 x A4 pages/min	1200 A4 pages/min or 2400 with extra folder			400 pages/min	400 piles/hr	2400 pages/min
Off-line sheet feeding speed	62 x A3 sheets/min	300 x A3 sheets/min					
Max. output speed (books/hour)	6,000 12,000 (with trimmer centre knife)				400	1500	
Max. book thickness	10mm (0.4")			60mm (2.36")		40mm (1.57")	
Min. book thickness	8 pages (2 sheets)				2mm (.08")		
Max. book size	320 (spine) x 225 mm (12.6 x 8.9")						320 (spine) x 280 mm (12.6 x 11")
Min. book size	97 (spine) x 119 mm (with centre knife) (3.8 x 4.7")			210 (spine) x 119mm (8.3 x 4.7")		120 (spine) x 140 mm (4.72 x 5.5")	
Min. sheet weight	50 grams /square metre (40 grams with extra folder). 13.4lbs bond (10.6lbs with extra folder)						
Stitching heads	Max. 4 heads - flat or loop stitch with 14mm (0.55") crown length. Round section wire 0.4 - 0.6mm (16 - 24 thou) diameter				N/A		
Gluing system	Not available		ISG cold glue	ISG cold, + hot melt glue	hot melt EVA or PUR		
Trim	Front knife: up to 27mm (1.06") Side knives: up to 20mm (0.8")				Optional		
Maintenance	Minimal maintenance requirements						
Operator interface	Graphical touch screen with multi-languages for system set-up, operation, and operator feedback.						

Smart-binder Products



**NEW
'PLUS'
Model**

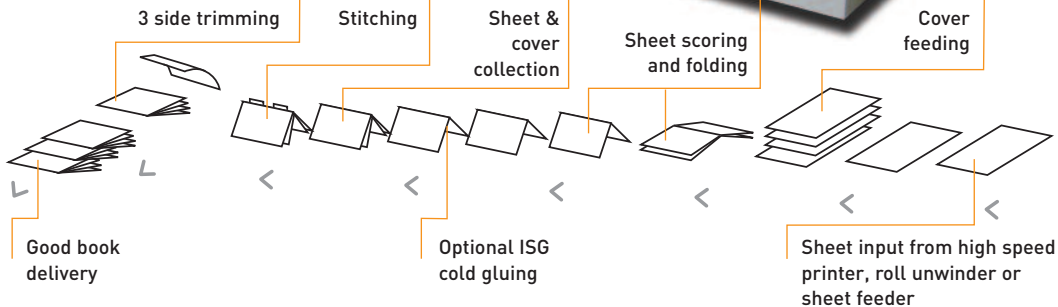

Smart-binder system

The Smart-binder systems are all based upon IBIS's unique saddle-stitcher which was launched in 2004. Models SB-1 and SB-2 produce wire-stitched books only. Models SB-3 and SB-4 also include ISG cold gluing.

The Smart-binder models SB-4 and SB-5 include an additional perfect binder for thicker 'perfect-bound' book production in addition to saddle-bound books. The SB-4 includes a perfect binder directly after the saddle-stitcher. The SB-5 includes a perfect binder which is separate from the saddle stitcher.

Smart-binder SB-1, SB-2 and SB-3

- For high-quality saddle-bound booklets.
- 'On-the-run' re-loading of cover sheets.
- SB-3 includes ISG cold gluing module to produce saddle-glued books.
- Upgradable to SB-4 or SB-5.

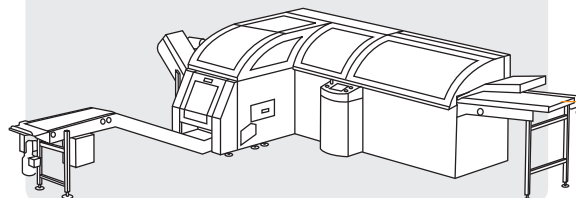

Sheet input from high speed printer, roll unwinder or sheet feeder

Smart-binder SB-4 One-stop-shop

The ultimate, flexible book-finishing system

- For saddle-stitched booklets, saddle-bound ISG cold-glued booklets and perfect-bound books made from ISG-glued signatures.
- In-line thick-book trimming.

Sprint-binder (600S or 2000J)
Perfect-binder

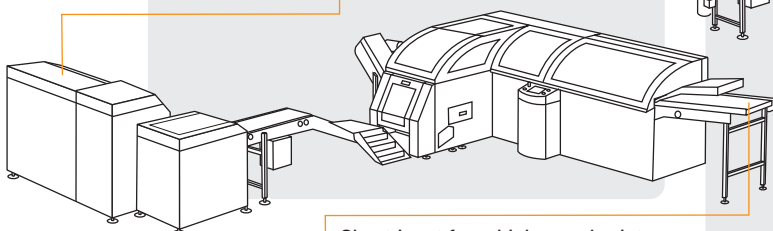

Sheet input from high speed printer, roll unwinder or sheet feeder

Smart-binder SB-5 One-stop-shop

- For saddle-stitched booklets, saddle-bound ISG cold-glued booklets and conventional Perfect-bound books.
- In line thick-book trimming.

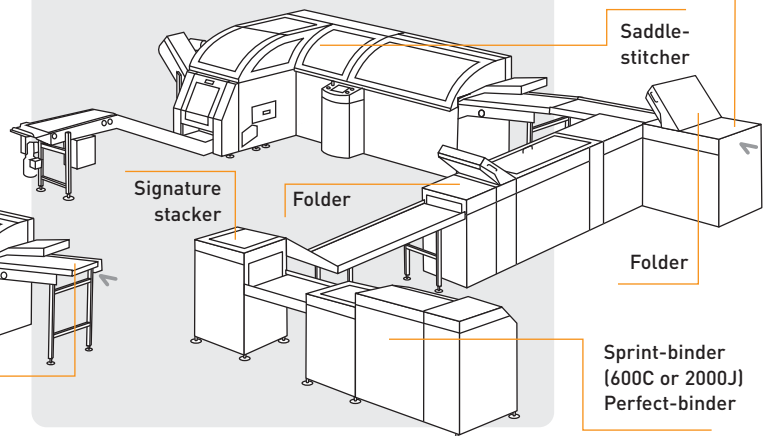

Sheet input from high speed printer, roll unwinder or sheet feeder

Saddle-stitcher

Signature stacker

Folder

Folder

Sprint-binder (600C or 2000J)
Perfect-binder

Perfect Binder Products

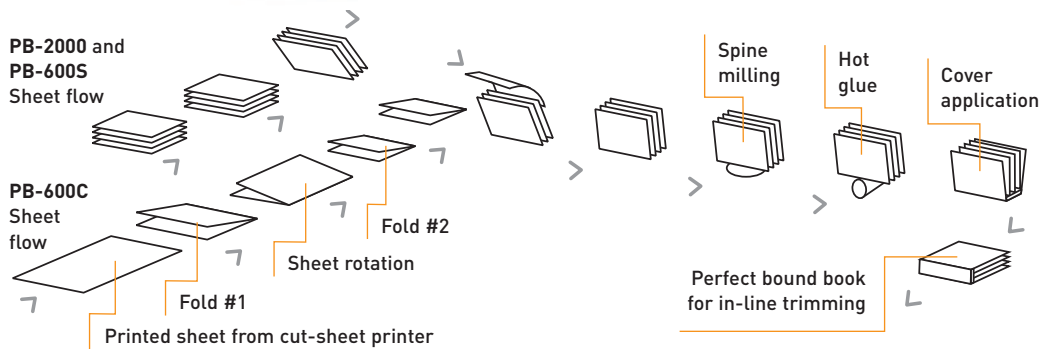

Sprint-binder PB-600S

400 books/hour

- For use in-line with a medium speed digital CF web printer and web cutter/stacker.

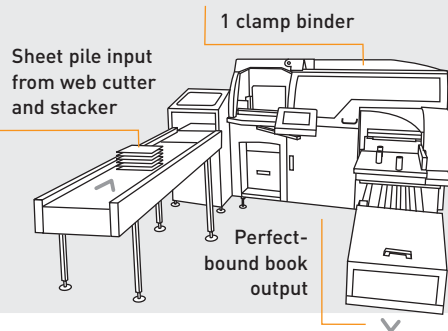

Sprint-binder 2000JS

1500 books/hour

- For use in-line with a high speed CF web printer and web cutter/stacker book block feeder.

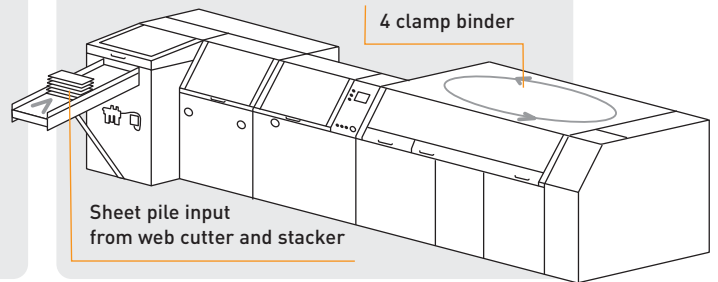

Sprint-binder PB-600C

400 books/hour

- For use in-line with a digital cut-sheet printer.
- Fully variable book thickness on-the-run.
- Includes option for multiple folders for varying book format sizes on-the-run.

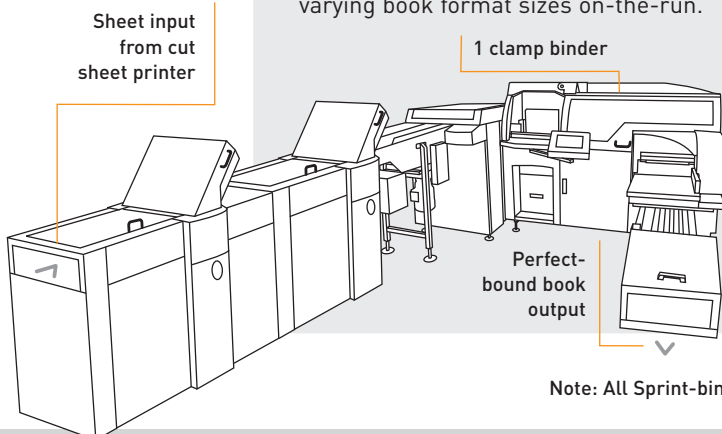

Sprint-binder 2000JC

1500 books/hour

- For use in-line with a high speed CF web printer and web cutter.

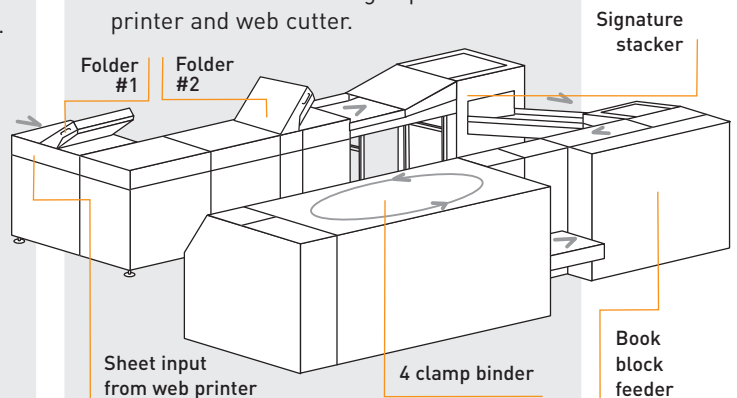

Note: All Sprint-binders provide fully automated book thickness and format changes.

Customer testimonials

Mr Hees, Print Manager
R & V Insurance, Germany

R & V produce large numbers of individually personalised insurance documents, each up to 128 pages thick. These are made using the Smart-binder SB-3's unique ISG cold gluing system (which offers many advantages over wire stitching for this application) and multiple-bin selective feeding of a cover sheet with cut-out



window. According to print manager, Mr Hees, the system performs 'trouble-free'.

Mr Esser, Esserdruck
Stuttgart, Germany

"Digital media has given both our business and living environment new impetus which will continue in future. We are continually searching for new possibilities which our customers can profit from. An example of this is the manufacturers of hand-books, brochures and product operation manuals with variable "On-Demand" contents. The addition of the IBIS saddle-stitcher system (connected in-line to the CF digital printer) enables us to fulfil this requirement in the optimum way."

Tommy Morgan, Head Of Operations
IOS, Dagenham, London UK

"Our new off-line Smart-binder has already proven to be an effective high-speed saddle-stitcher for our personalised work and is better enabling us to meet our time-sensitive customer commitments for high quality bound documents."

Mr Zercher, Digital Print Supervisor
RR Donnelley, USA

"We've been using our Digi-stitcher heavily for the past four years. We are coming off one of our peaks where we produced over 500,000 books with pages ranging between 16 and 128. Each of these books are variable in nature in that every page is different and every book has a different page count. We are now in the process of looking to purchase a second IBIS line."

Steve Ellithorpe, Operations Manager
O'Neil Data Systems Inc., Los Angeles

"We have built up years of experience in running four IBIS Smart-binders at our production site in LA. These machines proved to be solid performers and capable of operating at peak production rates over a long time periods. Our first thought, therefore, when setting up a new O'Neil facility this year in Plano, Texas was to look to IBIS for additional finishing equipment.

We recently installed two additional Smart-binder systems in Plano which are now operational and contributing well to the effective start-up of this



large new production site. We are pleased to have become one of the largest users of IBIS Smart-binders in the USA."

Our reseller partners for digital print finishing include:





Commitment statement

To provide solutions that will give you advantage over your competitors, I commit to you that we will:

- Act with openness and integrity in all our dealings with you, respond within one working day and respect the confidentiality of information you give us.
- Only sell to you if we are confident that we can satisfy your requirements.
- Review how our equipment may be customised to suit your specific needs.
- Test and demonstrate your finishing job prior to sale, if needed.
- Continue to work with you after installation until we achieve pre-agreed system performance.
- Give you continued technical support in the future.

I look forward personally to helping you put into operation a complete and highly-effective book-finishing system which will increase your competitiveness and grow your business.

For further information, don't hesitate to call me.

Phone: +44 1494 561 950, E-mail: John.Cracknell@ibis-bindery.com

John Cracknell
Managing Director, IBIS Bindery Systems



Comprehensive service and support

A commitment to engineering excellence

Worldwide system installations

Contact us

IBIS UK (Head Office)

Contact: John Cracknell (Sales)
Martin Reed (Customer support)
Phone: +44 1494 561 950
Fax: +44 1494 561 951
Address: 9, The Gateway Centre
High Wycombe
HP12 3SU, UK
E-mail: sales@ibis-bindery.com

IBIS USA

Contact: Don Piontek (Sales)
Phone: +001 952 937 5100
Fax: +001 952 974 0467
Address: 14116 Westridge Drive
Eden Prairie
MN 55347-1732
USA
E-mail: don.piontek@ibis-bindery.com

CP Bourg USA

Phone: +001 508 998 2171
Address: 50 Samuel Barnet Blvd
New Bedford
MA 01745
USA
E-mail: CPBourg@worldnet.att.net

www.ibis-bindery.com