

Data Sheet: Optional corner hole-punch module CHP-100

The single hole-punch system CHP-100 may be installed in the Smart-binder trimmer to punch a hole in either the left or right corner of each booklet.

It is installed in a location such that the hole is punched at the same time as the book front edge is trimmed. The punch is driven by the downward motion of the upper trimmer knives and this drive may be easily inhibited by a quick manual adjustment of the drive arm. The punch is spring driven back up out of the book as the knives move back up to their top position.

The system includes a set of new additional pneumatic-driven side joggers, which ensure that each book is correctly side-registered before the hole is punched.

The hole-punch can be supplied in three different versions:

- CHP-100H punches a hole in the head side of the booklet
- CHP-100F punches a hole in the foot side of the booklet
- CHP-100HF punches a hole in both the head and/or the foot side of the booklet

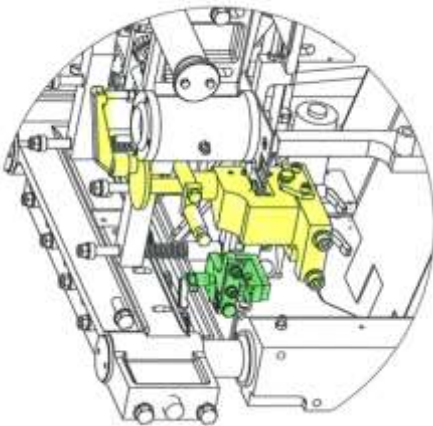

Hole punch installed in trimmer

Hole-punch CHP-100 Specifications

- Hole diameter : 6mm
- Finished trimmed booklet size = 297 spine length x 210 width (A4)
- Book thickness: 0 – 3mm
- Hole position measured from side-edge of book: 8.5-10mm
- Hole position measured from spine-edge of book : 8.5 – 26mm
- Speed: defined by Smart-binder trimming speed (does not introduce slow-down)

IBIS Innovation: Moving you ahead

IBIS Integrated Bindery Systems Limited, 9 The Gateway Centre, Coronation Road , Cressex Business Park, High Wycombe, HP12 3SU, UK. Tel.: +44 (0) 1494 561950 Fax: +44 (0) 1494 561951

Email: info@ibis-bindery.com

Web site: www.ibis-bindery.com

Company registered in England, number 03703149. UK VAT Registration number 697 9379 42.

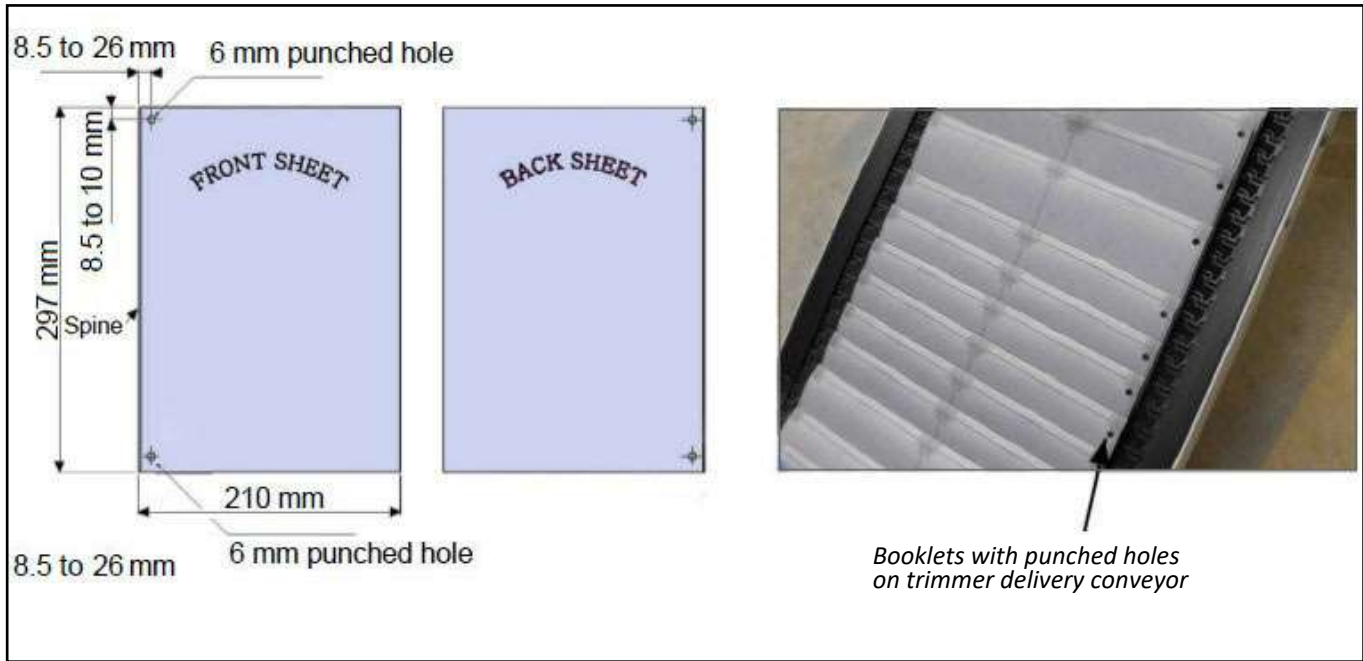

IBIS Innovation: Moving you ahead

IBIS Integrated Bindery Systems Limited, 9 The Gateway Centre, Coronation Road , Cressex Business Park, High Wycombe, HP12 3SU, UK. Tel.: +44 (0) 1494 561950 Fax: +44 (0) 1494 561951

Email: info@ibis-bindery.com

Web site: www.ibis-bindery.com

Company registered in England, number 03703149. UK VAT Registration number 697 9379 42.